

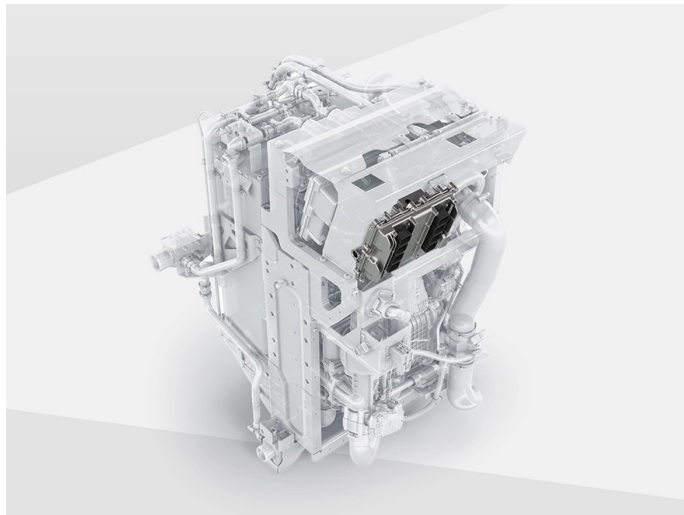

Energy

Fuel cell control unit

Control unit for automotive fuel cell systems and hydrogen storage systems

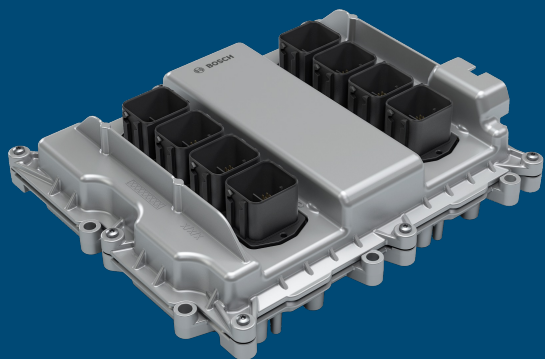

Dynamic

Closed-loop control algorithms with model-based, self-learning software functions

Flexible

Configurable, scalable hardware and software portfolio for made-to-measure solutions

- Comprehensive package of software functions for dynamic operation of fuel-cell systems that conserves components
- Self-learning, model-based software functions for efficient, economical data calibration and a quick time-to-market
- Configurable, scalable hardware concept for optimum adaptation to the respective application in passenger cars or commercial vehicles
- Easy integration into new and existing E/E architectures
- Hardware security module for improved cybersecurity and tuning protection